

WEIGHT TRANSMITTER

Ideal for all applications that require basic weighing, local indication & integration with PLC / PC software.

An affordable weighing controllers for

- ✓ OEM's
- ✓ EPC's
- ✓ PLC Integrators
- ✓ Turn-key solution provider



Easy to use & well accepted by international customers



TECHNICAL SPECIFICATIONS

DISPLAY : 5 digit bright red color LED display

A/D CONVERTER : Internal 20-bit, External 16-bit resolution

Conversion Rate : 10 Samples/Sec

LOADCELLS : Drives 6 Load cells of 350 Ω

POWER SUPPLY : 24V DC/1.5 A , Power Consumption : 13 watts max

DIMENSION : DIN STD 48 x 96 mm, Depth-122 mm
Panel cutout 45 x 92 mm

MODEL	WT-10 N	WT-10 D
ANALOG OUTPUT	0-5V/0-10V, 0 -20mA 1-5V/2-10V, 4-20mA	0-5V/0-10V, 0 -20mA 1-5V/2-10V, 4-20mA
SERIAL PORTS	RS232 / RS485 (Half Duplex)	RS232 / RS485 (Half Duplex)
PROTOCOLS	MODBUS RTU/ASCII/ Request/Dump	MODBUS RTU/ASCII/ Request/Dump
DIGITAL INPUT	----	2 INPUTS High logic (5-24V DC)
DIGITAL OUTPUT	----	2 OUTPUTS Potential free contact (24V DC / 1A)

CONNECTION DETAILS

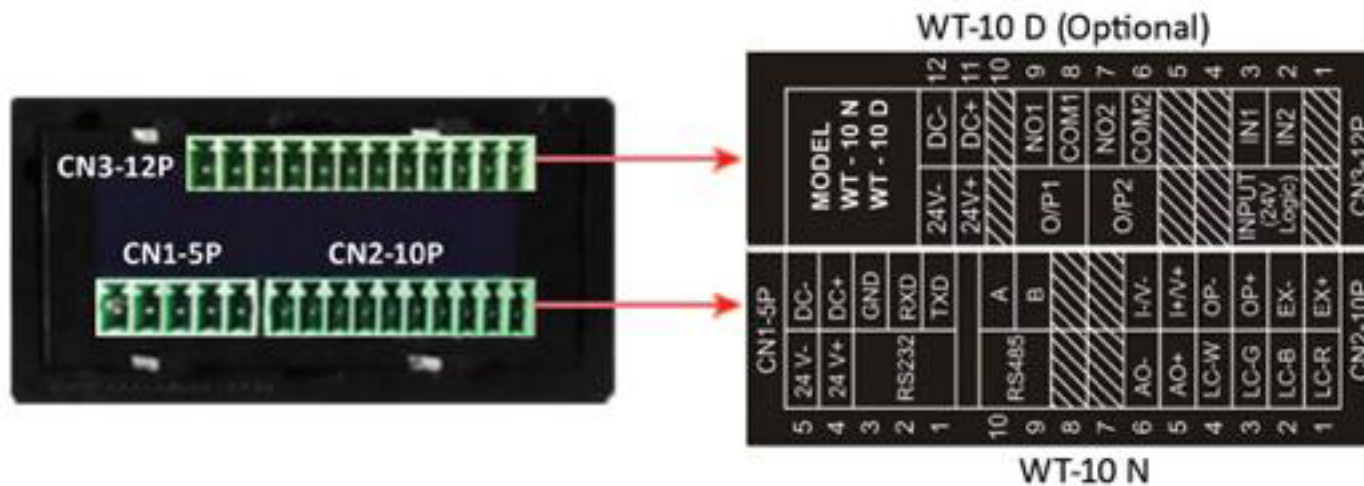

APPLICATION

- Silo Weighing
- Platform Scales
- Tank Weighing
- Bench Scales
- PLC integration

SENSOTECH

2/675, "THE PALMS", 1ST CROSS STREET,
RANGA REDDY GARDEN, NEELANKARAI,
CHENNAI - 600 041.

Phone: 044-24494305

Mobile: 9380560667, 9884869600

E-mail: sales@sensotechindia.com

sensotechindia@gmail.com

Website: www.sensomaticloadcell.com