

# MODEL : BBM-L

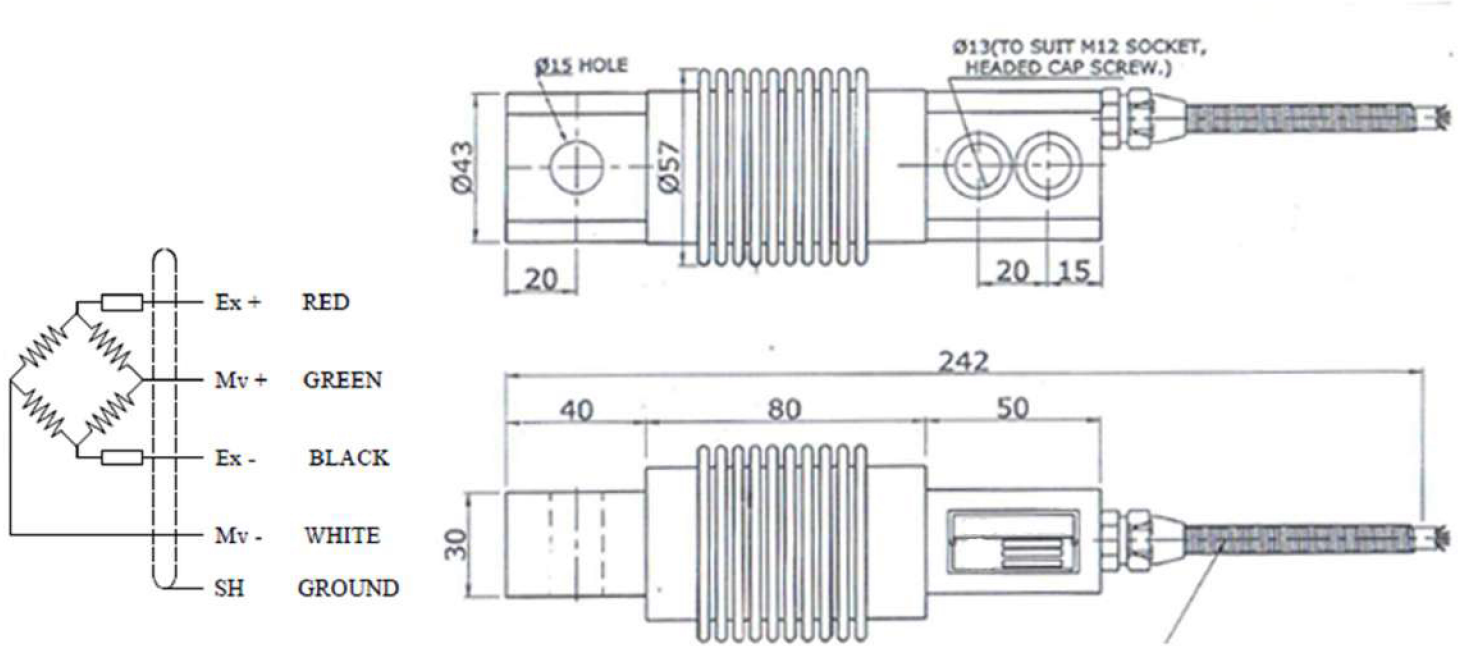

## Dimension



## MODEL : BBM-L

### Performance Data

Capacity Range (in Kg)	100/150/200/300/400/500/700
Capacity Range ( in tf)	1
Nominal Sensitivity (mv/V)	2±0.25%
Zero Signal Tolerance	0 ± 2%
Input Resistance	350±5Ω
Output Resistance	350±3Ω
Recommended Excitation Voltage	10 VDC
Maximum Excitation Voltage	15 VDC
Linearity Deviation (as % of Full Scale)	< ± 0.020
Repeatability (as % of Full Scale)	< ± 0.020
Hysteresis (as % of Full Scale)	< ± 0.020
Creep (as % of Full Scale) in 30 min	< ± 0.020
Effect of Temperature on Zero ( % / °C)	± 0.002
Effect of Temperature on Span ( % / °C of Load)	± 0.001
Compensated Temperature Range	-10 to + 40°C
Operating Temperature Range	-20 to +70°C
Combined Error (as % Full Scale)	< ± 0.025 max
Isolation Resistance (@ 50 VDC)	> 1000 M Ω
Max. Limit Force (as % of Full Scale)	150
Breaking Force (as % of Full Scale)	300
Lateral Load Limit (as % of Full Scale)	
Protection Class	IP 68
Material of Construction	High Nickel Alloy Steel

### Features

- ★ Low Profile Design
- ★ Low Deflection & Creep
- ★ Excellent Overload Capability
- ★ Standardised output for Multi-Transducer Application

### Optional

- ★ Explosion proof Version Suitable for Group I, IIA, IIB, IIC & meet Temperature Class T4

### Application

- ★ Low profile floor scale, Tank/Hopper weighing, Overload Track Scale, Dynamic Weighing/Process Automation / Bagging Machine, Concrete Batching Machinery/Patient Bed Weighing/ Health monitoring

### Sensotech

2/675, " THE PALMS", 1st Cross Street, Ranga Reddy Garden, Neelankarai, Chennai-600115

(+91) - 9176070667 / 9790922667 / 9952020667 / 9566022667

Mail : sales@sensotechindia@gmail.com / sensotechindia@gmail.com

Website : <https://sensomatic.co> / <https://sensomaticloadcell.net>